

OPERATING INSTRUCTIONS

BT 6.30 - BT 6.37

INSTALLATION

1/ Unpack the clock and check its condition. In case of damage make a claim immediately to the shipping company.

2/ Open the casing by depressing the button (5) located below the rear part of the clock.

3/ Fix the wall plate.

4/ For the connection of mains operated or slave clocks see chapter CONNECTION.

5/ Set the clock on the wall plate.

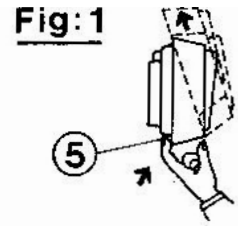

FIG. 1

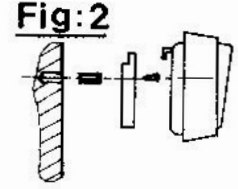

FIG. 2

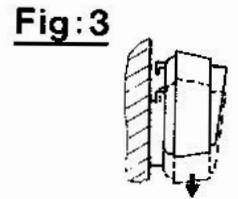

FIG. 3

SETTING ON TIME - FIG. 4

1/ Set the minutes to 00 by activating the lever (13) in arrow direction.

2/ Set the hours to 00 by activating the lever (15) in arrow direction. On clocks with 12 h. display set the hours to 12 PM. The clock is at 12 PM when the hole on the cam (19) on the left of the clock is on the front.

3/ Set the day of the month to 1 by activating lever (17) in arrow direction.

4/ Calendar : Set the mark (16) on the year wheel (right side, lower part of the clock) on the current year by activating lever (20) in arrow direction. Caution : This adjustment activates the month display; check the month while setting the year.

i.e. : To show January 1983, set the red arrow on the line separating 1982 from 1983.

5/ Month : Set to the month by activating lever (20).

6/ Date : Set to the day of the month by activating lever (17) in arrow direction.

7/ Weekday : Set to the day by activating lever (26) in arrow direction.

8/ Hour : Set the hour by activating lever (15) in arrow direction.

9/ Minute : Set the minute by activating lever (13) in arrow direction.

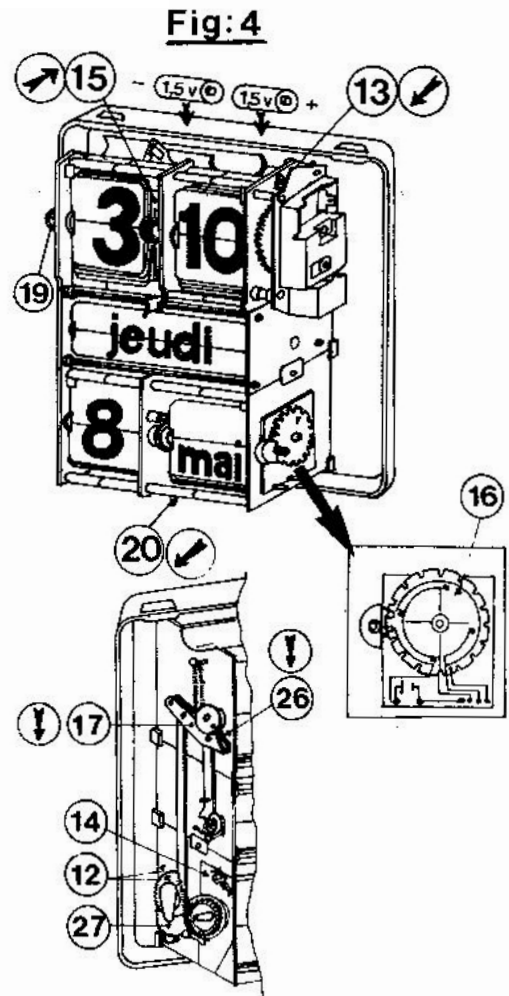

CAUTION

- Never attempt to move the flaps by hand.
- The automatic calendar motor is switched off by safety switch (14) when housing is opened.
- if the date does not change every 24 h. this is caused by the locking of lever (17) in middle of its stroke by the automatic calendar resetting motor. In this case set in correspondence the arrow (12) in front of mark (14) by turning the wheel (27) manually.

DAYLIGHT SAVING TIME :

To advance 1 h. push once on lever (15) the minutes being between 00 and 03.

To retard 1 h. set the switch (8) on OFF.

SETTING IN OPERATION

Quartz movement

1/ Battery operated quartz clocks :

Set the 2 X 1,5 V. alkaline batteries taking care of the correct polarity, set the switch (8) on ON, the clocks starts immediately.

To synchronize on the second :

Set the clock manually 1 minute early ; on the flap fall, press the "Stop" button (7) and keep it depressed ; on the time signal release it ; the clock is synchronized on the second.

2/ Mains operated quartz clocks :

Set the switch (8) on ON position : the clock starts immediately. To synchronize on the second : id. 1 above.

Fig. 5

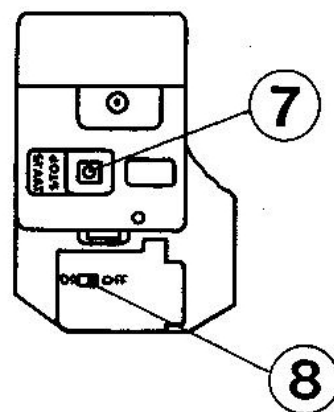

Slave movement

Wait for 2 impulses in order to get the movement on the right polarity and set the clock on time according to above.

CONNECTION

All electrical connections are made on the wall plate.

The clock is automatically connected by plug-in when set on the wall plate.

The motor of the automatic calendar is supplied by 2 alkaline batteries R 14. Before the setting on time, set the batteries as shown on fig. 4.

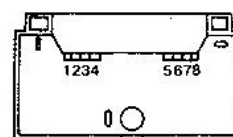

Power reserve quartz

Connect the mains wires on 2 & 3.

The clock operates on voltages from 100 to 250 V. AC.

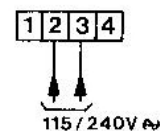

12/24 V, min. and 1/2 min. impulse slave movement (type 5)

12 V. imp. : 2 shunts between 5-6 and 7-8. I = 27 mA.

24 V. imp. : 1 shunt between 6-7. I = 13 mA.

48 V. imp. : Insert 1 2200n resistor between 6-7. I = 13 mA.

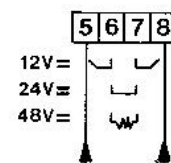

1/2 min. serie[s] slave movement (type 6)

Set a 100R resistor between 5-8.

If necessary adapt the value of the resistor. Coil consumption : 45 mA, 3 V.

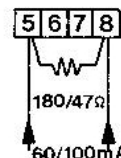

Hourly reset slave movement SR2 21/31 V. min. imp.

(Simplex / IBM, type 7) and 24 V. DC non polar mvmt

Caution : Make sure that the impulse polarity is correct.

Consumption : 45 mA at 24 V.

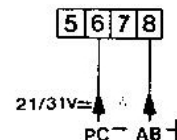

The SR2 movement can be adapted to SR3 (3 wires) by removing the diode located on the PCB of the movement coil.

Connection becomes :

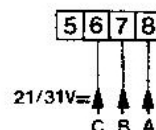

CAUTION

For any transport : Put a protective sheet onto the flaps : close the cover, put the clock into a nylon bag then in the original packing or a double packing.

We will not be responsible of any damage due to incorrect packing.

For any claim or spare-parts order state on your request the control and model numbers of the clock.